



Vacuum gauges

The Bourdon spring vacuum gauges are used to measure the vacuum in containers or tanks held under vacuum, vacuum machine, plants for moving objects or materials with suction cups, and to control vacuum pumps. The Bourdon system vacuum meters can be supplied dry or bathed in glycerin. Scale from 0 to 760 mm/Hg: tolerance 1% of the scale, or with different reading scale, Radial or rear attachment. Temperature range from -12 to +55°C.

Operation

A tubular plastic element, specifically the Bourdon spring is connected directly to the base of the attachment, forming a single piece. The liquid, (the pressure of which is to be measured), penetrates the Bourdon spring via a hole. With the increase in the fluid's pressure, the tubular spring deforms away from its original position (the Bourdon effect). The movement of the ends of the spring gives the vacuum measurement. For easier reading, this movement is amplified by a connecting lever and transmitted to the indicator. The instrument is protected by a metal case, and the dial and indicator are enclosed in transparent glass. The measuring organs are usually made of special copper alloys, or nickel chrome stainless steel. All of the vacuum meters shown are guaranteed by the safety regulations and measuring units in force.

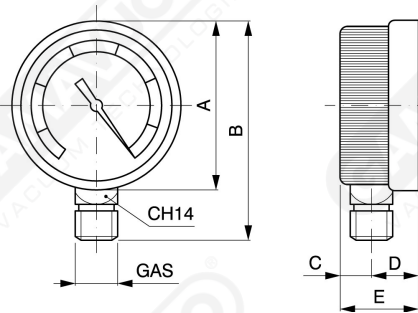

Art. SVMR 63/100

Art.	A	B	C	D	E	Gas
*SVMR 63	63	87	9	18	27	1/4"
*SVMR 100	100	125	11	26	37	1/2"

* For vacuum meters in glycerin baths ask for model VTR/G 63 and VTR/G 100.

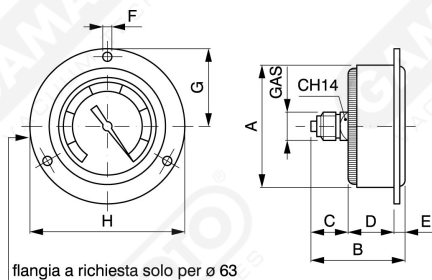

Art. SVM 40 - SVMF 63/100

Art.	A	B	C	D	E	F	G	H	Gas
SVM 40	40	43	18	25	-	-	-	40	1/8"
*SVMF 63	63	51	20	27	4	3.5	75	85	1/4"
*SVMF 100	100	52	21	26	5	4.5	116	132	1/2"

* For vacuum meters in glycerin baths ask for model VTF/G 63 and VTF/G 100.