



Vacuum pumps with lubrication G series - 40-80 mc/h

Characteristics

Gamavuto 40 to 80 m³/h lubricated vacuum pumps are characterized by a very simple design, by a strong, compact body and by a simple but efficient air cooling system. In the "G" series the electric motor is connected to the body of the pump through a flexible connector and this allows the use of different kinds of motors. They require only the bare minimum of maintenance since the recycling lubrication allows the oil to be changed or topped up only according to the actual operating times.

Installation

Connect up the vacuum circuit. Set up the electrical connections to the motor and check that the pump is rotating in the right direction. **WARNING!** If the electrical motor rotates in the wrong direction, the suction unit could be damaged.

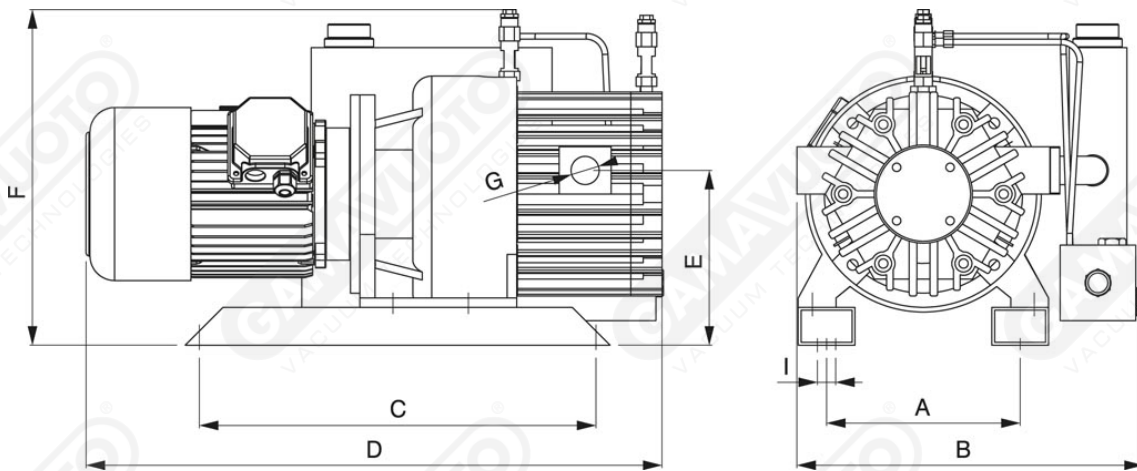

Art. GPOL 40/50/65/80 G

Art.	Vacuum flow		Final pressure ABS mbar/ass	Rpm		Motor power		Weight kg	A	B	C	D	E	F	G	I	Oil viscosity
	50 Hz Mc/h	60 Hz Mc/h		50 Hz g/min	60 Hz g/min	50 Hz Kw	60 Hz Kw										
GPOL 40/G	40	48	65	1450	1700	1.1	1.3	49	210	365	415	520	185	350	1"	12.5	
GPOL 50/G	50	60	65	1450	1700	1.5	1.75	55	210	365	415	560	185	350	1"	12.5	ISO 100
GPOL 65/G	65	78	65	1450	1700	1.5	1.75	60	210	365	415	580	185	350	1"	12.5	
GPOL 80/G	80	96	65	1450	1750	2.2	2.6	80	210	365	415	640	185	360	1-1/2"	12.5	ISO 150