

**Vacuum pumps with lubrication without recirculation G series - 5-20 mc/h**



**Characteristics**

Gamavuoto 5 to 20 m<sup>3</sup>/h lubricated vacuum pumps are characterized by a very simple design, by a strong, compact body and by a simple but efficient air cooling system. In the "G" series the electric motor is connected to the body of the pump through a flexible connector and this allows the use of different kinds of motors. In this version of the pump, the lubricant is in a transparent tank placed at the top and is equipped with a level switch which allows managing the possible lack of oil, which, once used for the normal process lubricant, is accumulated in the tank located below the discharge / silencer of the pump and is no longer put back into circulation, thus preventing any impurities (dust, liquids, etc.) not retained by the main filter during intake from accumulating and causing performance deterioration. Equipped with silencers which strongly reduce the noise level, these pumps can also be requested with a single-phase motor.

**Installation**

Connect up to the vacuum circuit. Set up the electrical connections to the motor and check that the pump is rotating in the right direction.

**WARNING!** If the electrical motor rotates in the wrong direction, the suction unit could be damaged.

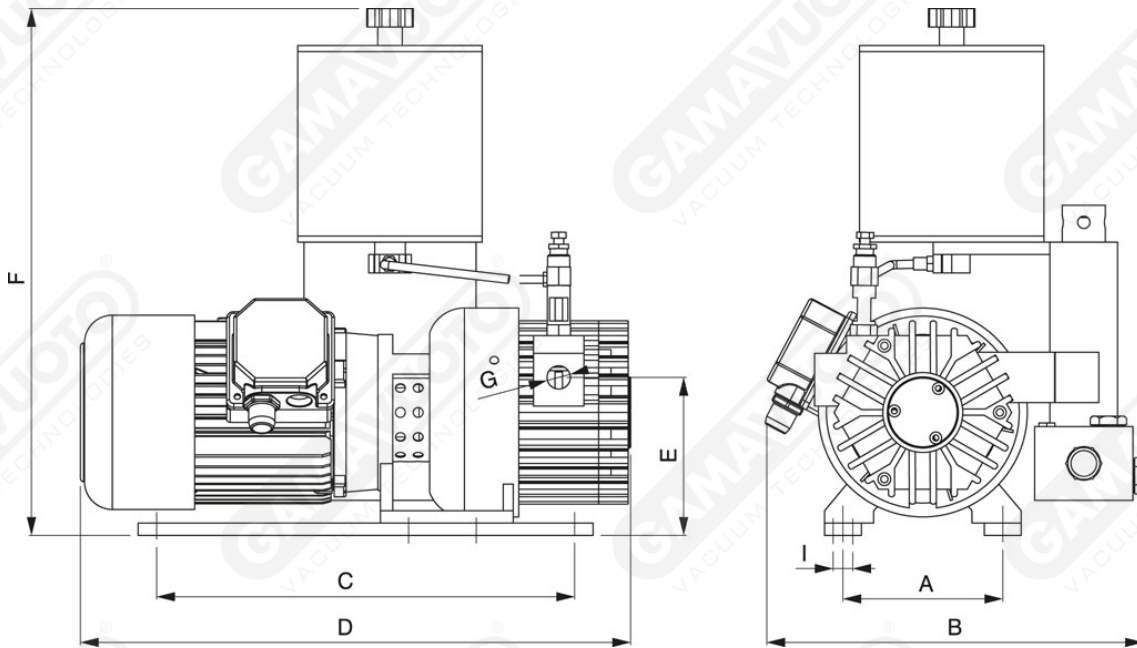

**Art. GPOL 5/10/15/20 GLP**

Art.	Vacuum flow		Final pressure ABS mbar/ass	Rpm		Motor power		Weight kg	A	B	C	D	E	F	G	I	Oil viscosity
	50 Hz Mc/h	60 Hz Mc/h		50 Hz g/min	60 Hz g/min	50 Hz Kw	60 Hz Kw										
<b>GPOL 5/GLP</b>	5	6	75	1450	1700	0.25	0.30	15	130	250	340	410	130	475	3/8"	8.5	ISO 32
<b>GPOL 10/GLP</b>	10	12	75	1450	1700	0.37	0.44	25	130	300	340	430	130	475	1/2"	8.5	
<b>GPOL 15/GLP</b>	15	18	65	1450	1700	0.55	0.65	28	130	300	340	450	130	475	1/2"	8.5	ISO 100
<b>GPOL 20/GLP</b>	20	24	65	1450	1700	0.55	0.65	32	130	300	340	470	130	475	1/2"	8.5	