

Vacuum pumps with lubrication and oil separator cartridge G series - 25-35 mc/h

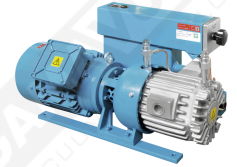

Characteristics

Gamavuoto 25 and 35 m³/h lubricated vacuum pumps are characterized by a very simple design, by a strong, compact body and by a simple but efficient air cooling system. In the "G" series the electric motor is connected to the body of the pump through a flexible connector and this allows the use of different kinds of motors and there is also an oil separator filter cartridge interchangeable placed on the exhaust that helps to reduce practically to zero smoke emissions. Equipped with silencers which strongly reduce the noise level, these pumps can also be requested with a single-phase motor. They require only the bare minimum of maintenance since the recycling lubrication allows the oil to be changed or topped up only according to the actual operating times.

Installation

Connect up to the vacuum circuit. Set up the electrical connections to the motor and check that the pump is rotating in the right direction.

WARNING! If the electrical motor rotates in the wrong direction, the suction unit could be damaged.

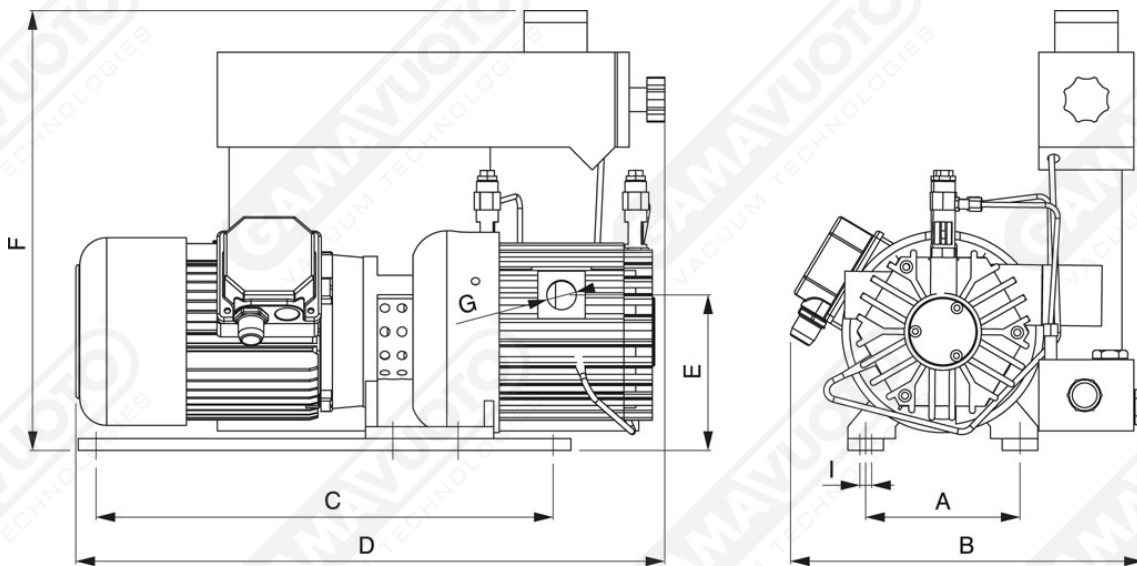

Art. GPOL 25/30/35 GD

Art.	Vacuum flow		Final pressure ABS	Rpm		Motor power		Weight kg	A	B	C	D	E	F	G	I	Oil viscosity
	50 Hz Mc/h	60 Hz Mc/h	mbar/ass	50 Hz g/min	60 Hz g/min	50 Hz Kw	60 Hz Kw										
GPOL 25/GD	25	30	65	1450	1700	0.75	0.90	33	130	290	385	470	130	280	3/4"	8.5	
GPOL 30/GD	30	36	65	1450	1700	0.75	0.90	35	130	290	385	490	130	280	3/4"	8.5	ISO 100
GPOL 35/GD	35	42	65	1450	1700	1.10	1.30	37	130	290	385	510	130	280	3/4"	8.5	