



High vacuum vane pumps - 105-151 mc/h

Characteristics

Gamavuoto oil injection single-stage vacuum pumps are the result of many years of experience in the vacuum technology sector, making constant adjustments to the needs of industry and the environment. The vast range of their performances (capacity from 5 mc/h to 250 mc/h) allows every user to find a pump to meet all their needs. Here is a list of the main characteristics:

- Can be used in any pressure range from 400 mm Hg to 759.5 mm Hg.
- On request low depression values.
- Low noise level. Little vibration.
- Efficient air cooling, ease of mounting
- Strength.
- Easy to maintain.
- Can be adapted to solve many problems, because of the vast range of accessories.
- Working temperature from 0°C to +50°C.

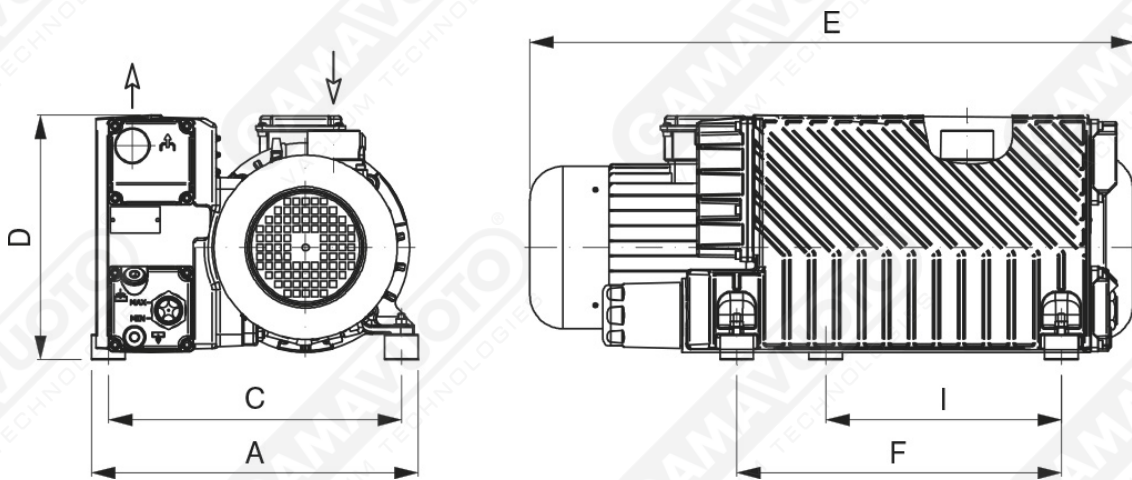

Art. GPZL 106/106 K Zero/151/151 K Zero

Art.	Vacuum flow		Final pressure ABS mbar (ass.)	Rpm		Motor power		Weight kg	A	B	C	D	E	F	G	H	I
	50 Hz Mc/h	60 Hz Mc/h		50 Hz g/min	60 Hz g/min	50 Hz Kw	60 Hz Kw										
GPZL 106	106	127	0.1	1400	1700	2.2	3.7	70	392	315	352.5	292	706	390	1-1/2"		
GPZL 106 K Zero*	106	127	4	1400	1700	2.2	3.7	70.5	392	315	352.5	292	705	390	1-1/2"		
GPZL 151	151	181	0.1	1400	1700	3.3	3.7	82	392	315	352.5	292	743	390	1-1/2"	1-1/4"	283
GPZL 151 K Zero*	151	181	4	1400	1700	3.3	3.7	80	392	315	352.5	292	747	390	1-1/2"		

* This version of the pump is marked out by the capability to keep as low as possible the oil temperature and therefore to have a better behaviour during the operation