



Pompe per vuoto con lubrificazione - 5-10 mc/h

Characteristics

Gamavuoto 2 and 4m³/h lubricated vacuum pumps are characterized by a very simple design, by a strong, compact body and by a simple but efficient air cooling system. They require only the bare minimum of maintenance since the recycling lubrication allows the oil to be changed or topped up only according to the actual operating times.

Installation

Connect up the vacuum circuit. Set up the electrical connections to the motor and check that the pump is rotating in the right direction. **WARNING!** If the electrical motor rotates in the wrong direction, the suction unit could be damaged.

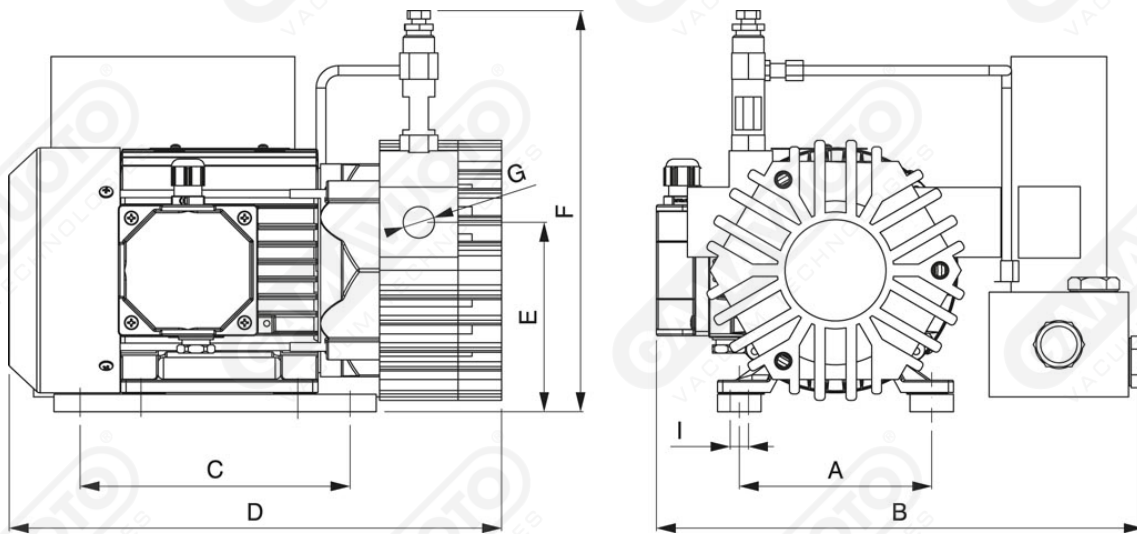

Art. GPOL 5/10

Art.	Volume aspirato		Press. finale mbar/ass	Velocità		Potenza motore		Peso kg	A	B	C	D	E	F	G	I	Viscosità olio
	50 Hz Mc/h	60 Hz Mc/h		50 Hz g/min	60 Hz g/min	50 Hz Kw	60 Hz Kw										
GPOL 5	5	6	75	1450	1700	0,25	0,30	14	115	245	155	260	120	245	3/8"	8,5	ISO 32
GPOL 10	10	12	75	1450	1700	0,37	0,44	20	115	265	155	310	120	270	1/2"	8,5	ISO 100